

City of Hendersonville

Braced / Shear Wall Construction Requirements

This document is designed to clarify, and hopefully simplify, some of the applicable provisions contained within the 2006 IRC with respect to braced and/or shear walls in detached one & two family dwellings. This handout is intended to be a supplement to the current and applicable code and not to set aside any of the basic technical requirements of that code. For the record, the City of Hendersonville has a Basic Wind Speed of 90 mph and is in Seismic Design Category C; although Section R301.2.2 exempts detached one & two family dwellings from the seismic requirements of the code.

The current prescriptive requirements for braced wall panels are primarily designed around slab on grade construction and/or balloon framing. We recognize that these are not the normal construction practices in use in Middle Tennessee. Therefore we have attempted to incorporate several reasonable and supportable solutions for typical CMU foundation walls and/or platform construction into this guide.

The code basically allows three (3) different methods to achieve the required compliance; **(1) prescriptive compliance, (2) engineered compliance and (3) proprietary products**. We have attempted to include all of these normally accepted methods within this document but have also included a fourth method, which we will refer to as **(4) locally accepted (LAM)**. Below is list of all of the compliance methods that will then be permitted in the City of Hendersonville and brief description of each.

1. **Prescriptive Compliance Method (PCM)** – Compliance with this method is achieved by complying with the prescriptive requirements contained in the code, primarily in Chapters 6 & 7 of the 2006 IRC, including any stated alternatives.
2. **Engineered Design Method (EDM)** – Compliance is achieved by a specific design performed by a State licensed design professional to include sufficient documentation describing the specific solution proposed and that it meets or exceeds the minimum prescriptive requirements of the 2006 International Residential Code.
3. **Proprietary Product Method (PPM)** – This method incorporates proprietary products and methods that have demonstrated their ability to meet or exceed the prescriptive requirements contained within the Code and therefore has been approved by an agency, association or testing facility which has been determined to be acceptable by the Authority Having Jurisdiction (AHJ).
4. **Locally Accepted Method (LAM)** – This method incorporates products, methods or combination of same that has successfully demonstrated to the Authority Having Jurisdiction (AHJ) that it meets and/or exceeds the performance requirements contained in the Code.

Prescriptive Compliance Method (PCM)

All exterior walls may install braced wall panels in accordance with the Prescriptive Compliance Method (PCM) as follows. This method is based on the applicable provisions of the **2006 INTERNATIONAL RESIDENTIAL CODE®**. All interior braced wall lines must be installed in accordance with Section R602.10.1.1. Non-continuous braced wall panels are to be constructed in accordance with the new Intermittent Bracing table contained within this handout. Continuous braced wall panels are to be constructed as noted herein. All code sections referenced herein should be considered as referring to the 2006 Edition of the International Residential Code unless otherwise noted.

Braced wall panels - General. Braced wall panels may be constructed in accordance with either the intermittent bracing methods specified in Section R602.10.3 or with the continuous sheathing methods specified in Section R602.10.5. Mixing of bracing methods may be permitted only as follows:

1. Mixing of bracing methods from story to story is permitted.
2. Mixing of bracing methods from braced wall line to braced wall line within a story is permitted, except for continuous sheathing methods which must conform to the additional requirements of Section R602.10.5.
3. Mixing of bracing methods within a braced wall line is only permitted for detached dwellings in Seismic Design Category C. The length of required bracing for the braced wall line with mixed sheathing types will have the higher bracing length requirement of all the types of bracing used.

Braced wall panels – Amount and location.

- **One Story or Top of Two or Three Story** - Located in accordance with Section R602.10 and at least every 25 feet on center but not less than 16% of braced wall line for Methods DWB, WSP, SFB, GB, PBS, PCP, and HPS from the Intermittent Bracing table.
- **First Story of a Two Story or Second Story of a Three Story** - Located in accordance with Section R602.10 and at least every 25 feet on center but not less than 16% of braced wall line for Method WSP or 25% of braced wall line for Methods DWB, WSP, SFB, GB, PBS, PCP, and HPS from the Intermittent Bracing table.

Braced wall panels - Length. For Methods DWB, WSP, SFB, PBS, PCP, and HPS, each braced wall panel shall be at least 48 inches (1219 mm) in length, covering a minimum of three stud spaces where studs are spaced 16 inches (406 mm) on center and covering a minimum of two stud spaces where studs are spaced 24 inches (610 mm) on center. For Method GB each braced wall panel shall be at least 96 inches (2438 mm) in length where applied to one face of a braced wall panel and at least 48 inches (1219 mm) where applied to both faces.







Exceptions:

1. Lengths of braced wall panels for continuous wood structural panel sheathing shall be in accordance with Section R602.10.5.
2. Lengths of alternate braced wall panels shall be in accordance with Section R602.10.6.1 or Section R602.10.6.2.

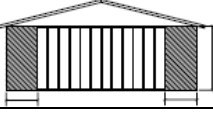
Braced wall Panels - Spacing. Spacing of braced wall lines shall not exceed 35 feet on center in both the longitudinal and transverse directions in each story.

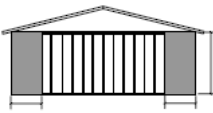
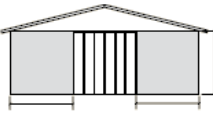
- Exception:** Spacing of braced wall lines not exceeding 50 feet shall be permitted where:
1. The wall bracing installed equals or exceeds the amount of bracing required by Table R602.10.1 multiplied by a factor equal to the braced wall line spacing divided by 35 feet and
 2. The length-to-width ratio for the floor or roof diaphragm does not exceed 3:1.

INTERMITTENT BRACING METHODS

METHOD	MATERIAL	MINIMUM THICKNESS	FIGURE	CONNECTION CRITERIA
LIB (1)	Let-in-bracing	1x4 wood or approved metal straps at 45° to 60° angles		wood: 2-8d nails per stud per Table R602.3.(1) metal: per manufacturer
DWB (2)	Diagonal wood boards at 24" spacing	5/8"		2-8d (2 1/2" x 0.113") nails or 2 staples, 1 3/4" per stud
WSP (3)	Wood structural panel	3/8"		6d common (2"x0.113") nails at 6" spacing (panel edges) and at 12" spacing (intermediate supports) or 16 ga. x 1-3/4 staples: at 3" spacing (panel edges) and 6" spacing (intermediate supports)
SFB (4)	Structural fiberboard sheathing	1/2" or 25/32" for 16" stud spacing only		1 1/2" galvanized roofing nails or 8d common (2 1/2"x0.131) nails at 3" spacing (panel edges) at 6" spacing (intermediate supports)
GB (5)	Gypsum board	1/2"		Nails at 7" spacing at panel edges including top and bottom plates; for exterior sheathing nail size, see Table R602.3(1); for interior gypsum board nail size, see Table R702.3.5
PBS (6)	Particleboard sheathing	3/8" or 1/2" for 16" stud spacing only		1 1/2" galvanized roofing nails or 8d common (2 1/2"x0.131) nails at 3" spacing (panel edges) at 6" spacing (intermediate supports)
PCP (7)	Portland cement plaster	See Section R703.6		1 1/2", 11 gage, 7/16" head nails at 16" spacing or 7/16", 16 gage staples at 6" spacing
HPS (8)	Hardboard panel siding	7/16"		0.092" dia., 0.225" head nails with length to accommodate 1 1/2" penetration into studs at 4" spacing (panel edges), at 8" spacing (intermediate supports)

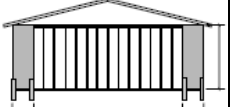
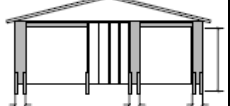
ABW	Alternate braced wall	See Section R602.10.3.1		See Section R602.10.3.1
PFH	Intermittent portal frame	See Section R602.10.3.2		See Section R602.10.3.2

Continuous wood structural panel sheathing. When Method WSP (3) as noted above all sheathable areas of all exterior walls, and interior braced wall lines, if and when required, including areas above and below openings, bracing wall panel lengths shall be in accordance with the following table. Wood structural panel sheathing shall be installed at corners in accordance with Figure R602.10.5. The bracing amounts noted above based on story height and location for Method WSP (3) are permitted to be multiplied by a factor of 0.9 for a wall with a maximum opening height that does not exceed 85 % of the wall height or a factor of 0.8 for a wall with a maximum opening height that does not exceed 67 % of the wall height.

CONTINUOUSLY SHEATHED WALL – BRACED WALL LENGTHS^{a, b, c}

MIN LENGTH OF BRACED WALL PANEL (inches)			MAX OPENING HEIGHT NEXT TO THE BRACED WALL PANEL (% of wall height)
8-foot wall	9-foot wall	10-foot wall	
48	54	60	100
32	36	40	85
24	27	30	65

- a. Linear interpolation shall be permitted.
- b. Full-height sheathed wall segments to either side of garage openings that support light frame roofs only, with roof covering dead loads of 3 psf or less shall be permitted to have a 4:1 aspect ratio.
- c. Walls on either or both sides of openings in garages attached to fully sheathed dwellings shall be permitted to be built in accordance with Section R602.10.6.2 and Figure R602.10.6.2 except that a single bottom plate shall be permitted and two anchor bolts shall be placed at 1/3 points. In addition, tie-down devices shall not be required and the vertical wall segment shall have a maximum 6:1 height-to-width ratio (with height being measured from top of header to the bottom of the sill plate). This option shall be permitted for the first story of two-story applications in Seismic Design Categories A through C.

Alternate braced wall panels - Adjacent to a door or window opening. Alternate braced wall panels constructed in accordance with one of the following criteria and the following figure are permitted to replace each 4 feet of braced wall panel as required by Section R602.10.4 for use adjacent to a window or door opening with a full-length header:

1. In one-story buildings, each panel shall have a length of not less than 16 inches and a height of not more than 10 feet as shown in the following figure. The wood structural panel sheathing shall extend up over the solid sawn or glued-laminated header and shall be nailed in accordance with the same figure also. Use of a built-up header consisting of at least two 2 x 12s and fastened in accordance with Table R602.3 (1) shall be permitted. A spacer, if used, shall be placed on the side of the built-up beam opposite the wood structural panel sheathing. The header shall extend between the inside faces of the first full-length outer studs of each panel with a clear span of not less than 6 feet and not more than 18 feet in length. The panels shall be supported directly on a foundation which

is continuous across the entire length of the braced wall line. The foundation shall be reinforced with not less than one No. 4 bar top and bottom. Where the continuous foundation is required to have a depth greater than 12 inches a minimum 12-inch-by-12-inch continuous footing or turned down slab edge is permitted at door openings in the braced wall line. This continuous footing or turned down slab edge shall be reinforced with not less than one No. 4 bar top and bottom.

2. In the first story of two-story buildings, each wall panel shall be braced in accordance with Item 1 above, except that each panel shall have a length of not less than 24 inches.

ALTERNATE BRACED WALL PANEL ADJACENT TO A DOOR OR WINDOW OPENING

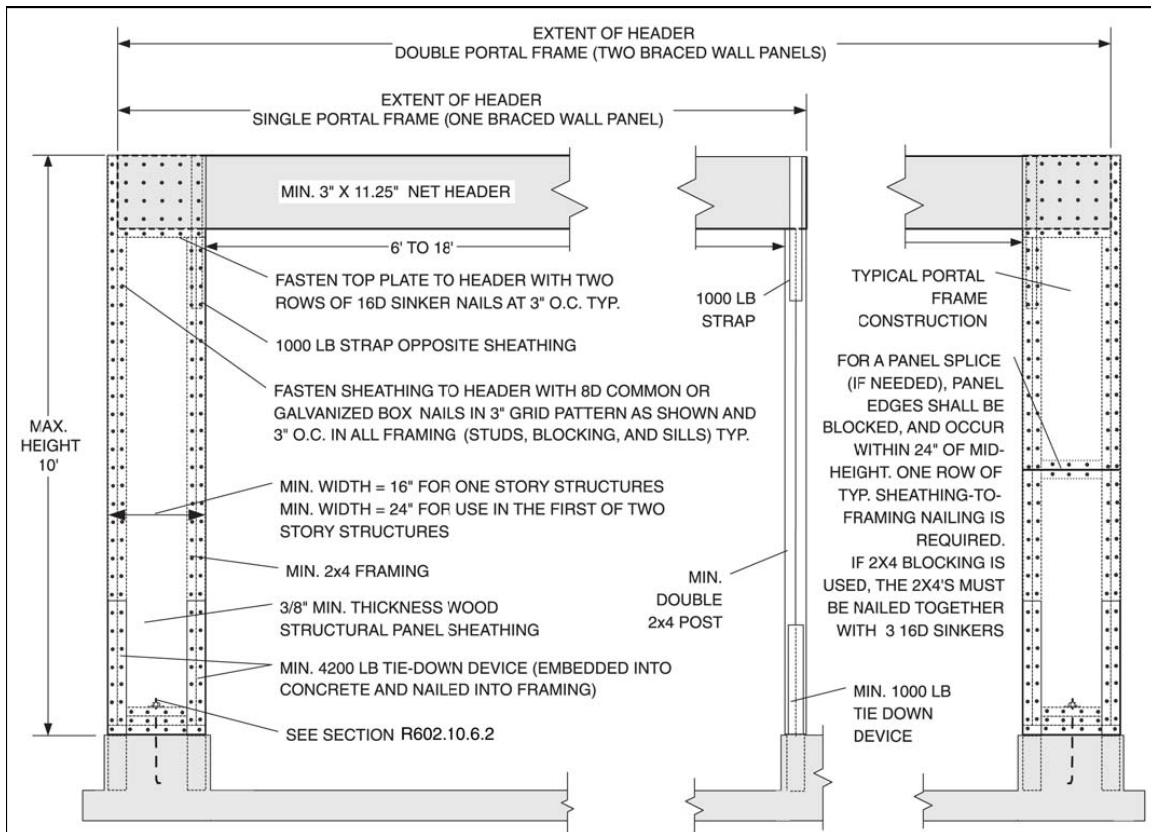

Engineered Design Method (EDM)

The provisions and/or requirements of the code were never intended to prevent the installation of any material or to prohibit any design or method of construction for wall bracing not specifically prescribed or called out for in the code, provided that such proposed alternative has been approved by the Authority Having Jurisdiction (AHJ). In most situations the Building Official or his designee will be considered the AHJ for the purposes of this method. If the AHJ finds that a particular alternative material, design or method of construction is satisfactory and complies with the intent of the provisions of this code, and that the material, method or work offered is, for the purpose intended, at least the equivalent of that prescribed in this code, it may be approved for use. Compliance with the specific performance-based provisions of the *International Codes* in lieu of specific requirements of this code shall also be permitted as an alternate.

For all requests for such approval of an alternative material, design or method of construction sufficient documentation must be provided to adequately justify that requested approval. In most situations, any required documentation must be completed by a State licensed design professional that has been determined by the State of Tennessee to be qualified to do such work. Any exceptions from this requirement must be approved by the AHJ on a case by case basis and based on the specific details of the requested exception.

Locally Accepted Method (LAM)

The following methods, products and/or applications have successfully demonstrated to the Authority Having Jurisdiction (AHJ) that they meet or exceed the true intent of the code, and for the purpose they are intended, are at least equivalent to that prescribed by code. Such approvals are granted in accordance with the **2006 International Residential Code, Section R104.9 Approved materials and equipment** and **Section R104.11 Alternative materials, design and methods of construction and equipment**. All of these approvals may at any time be reevaluated and then subsequently removed from the approved list should it be determined there is a problem with the supporting documentation, the applicable code provisions have changed or the actual installation does not perform as indicated. All code requirements or industry approved construction practices shall apply unless otherwise noted as part of the approval; the most stringent of these shall apply.

1) NAHB Alternate braced wall panel at garage door openings

Use is limited to either side of garage door openings when supporting a roof, or one story plus a roof. When calculating wall bracing amounts to satisfy the minimum requirements of Table R602.10.1 (1), the length of the alternate braced wall panel should be multiplied by a factor of 1.5. Use of this alternative must comply with the following criteria:

1. Braced wall panels must be a minimum of 24 inches in length and not more than 10 feet in height.
2. Braced wall panels must be sheathed on one face with a single layer of 7/16-inch-minimum thickness wood structural panel sheathing attached to the framing with 8d common nails at 3 inches on center. (See Figure NAHB #1 below).
3. The wood structural panel sheathing must extend up and over the solid sawn or glued-laminated header and be nailed to the header at 3 inch on center grid. (See Figure NAHB #1 below).
4. The header shall consist of a minimum of two solid sawn 2"x12"s or a 3"x11.25" glued-laminated header. The header shall extend between the inside faces of the first full-length outer studs of each panel (See Figure NAHB #1 below). The clear span of the header between the inner studs of each panel shall be between 6 feet and 18 feet in length.
5. A strap with an uplift capacity of not less than 1,000 pounds shall be used to fasten the header to the side of the inner studs opposite the sheathing face, except for wind exposure categories C or D where the strap uplift capacity must comply with Table R602.10.4.6.
6. A minimum of two bolts of not less than 1/2-inch diameter shall be installed in accordance with Section R403.1.6. A 3/16-inch by 2-1/2-inch by 2-1/2-inch steel plate washer is to be installed between the bottom plate and the nut of each bolt.
7. Braced wall panels must be installed directly on a foundation.
8. Where the alternate braced wall panel is located only on one side of the garage opening, the header shall be connected to a supporting jack stud on the opposite side of the garage opening with a metal strap with an uplift capacity of not less than 1,000 lbs. If the supporting jack stud is not part of a braced wall panel assembly, another 1,000 lbs strap must be used to attach the supporting jack stud to the foundation.

Refer to attached

**“NAHB ALTERNATIVE BRACED WALL PANEL
AT GARAGE DOOR OPENINGS
FIGURE NAHB #1”**

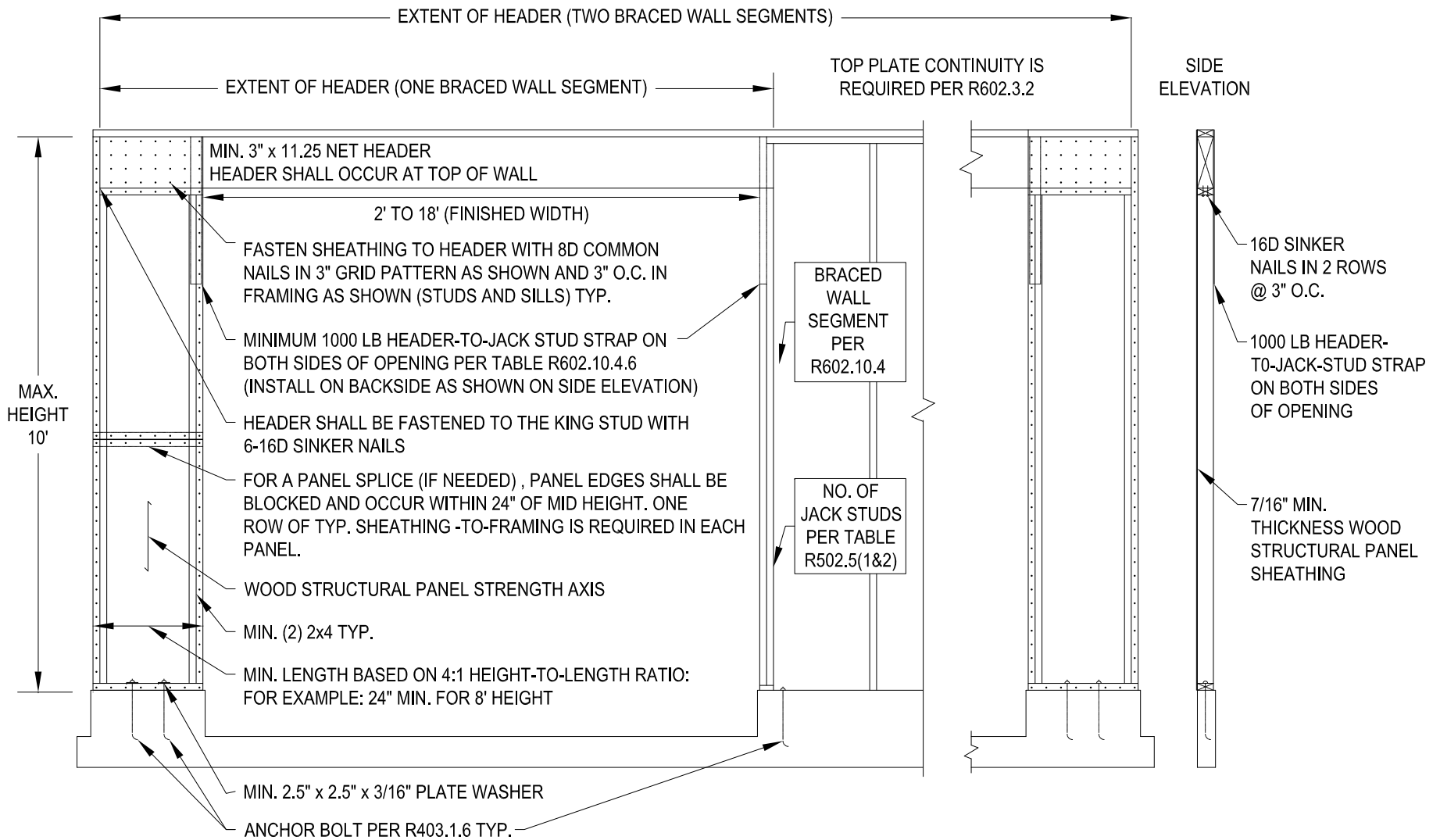

FOR WIND EXPOSURE CATEGORIES C AND D, ADDITIONAL JACK STUDS MAY BE REQUIRED PER TABLE R602.10.4.6

**NAHB ALTERNATIVE BRACED WALL PANEL AT GARAGE DOOR OPENINGS
FIGURE NAHB #1**

2) APA Narrow wall bracing with or without pony walls - Hold downs not required

Limited to walls with a 6:1 aspect ratio and continuous wood structural panel sheathing. All requirements for continuous wood structural panel sheathing contained in Section R602.10.5 shall apply unless otherwise noted. When utilizing pony walls refer to Table R602.10.4.6 for tension strap requirements. Un-reinforced masonry block foundations are limited to a maximum of three (3) courses.

TABLE R602.10.4.6
TENSION STRAP CAPACITY REQUIRED FOR RESISTING WIND PRESSURES
PERPENDICULAR TO 6:1 ASPECT RATIO WALLS^{a,b}

Minimum Wall Stud Framing Nominal Size and Grade	Maximum Pony Wall Height (ft)	Maximum Total Wall Height (ft)	Maximum Opening Width (ft)	Basic Wind Speed (mph)					
				85	90	100	85	90	100
				Exposure B			Exposure C		
				Tension strap capacity required (lbf) ^{a,b}					
2x4 No. 2 Grade	0	10	18	1000	1000	1000	1000	1000	1000
			9	1000	1000	1000	1000	1000	1275
			16	1000	1000	1750	1800	2325	3500
	1	10	18	1000	1200	2100	2175	2725	DR
			9	1000	1000	1025	1075	1550	2500
			16	1525	2025	3125	3200	3900	DR
			18	1875	2400	3575	3700	DR	DR
			9	1000	1200	2075	2125	2750	4000
			16	2600	3200	DR	DR	DR	DR
	2	12	18	3175	3850	DR	DR	DR	DR
			9	1775	2350	3500	3550	DR	DR
			16	4175	DR	DR	DR	DR	DR
4	12	9	1000	1000	1325	1375	1750	2550	
		16	1650	2050	2925	3000	3550	DR	
		18	2025	2450	3425	3500	4100	DR	
		9	1125	1500	2225	2275	2775	3800	
		16	2650	3150	DR	DR	DR	DR	
		18	3125	3675	DR	DR	DR	DR	
2x6 Stud Grade	2	12	9	1000	1000	1325	1375	1750	2550
			16	1650	2050	2925	3000	3550	DR
			18	2025	2450	3425	3500	4100	DR
	4	12	9	1125	1500	2225	2275	2775	3800
			16	2650	3150	DR	DR	DR	DR
			18	3125	3675	DR	DR	DR	DR

a. DR = not permitted

b. Strap shall be installed in accordance with manufacturer's recommendations

RB160

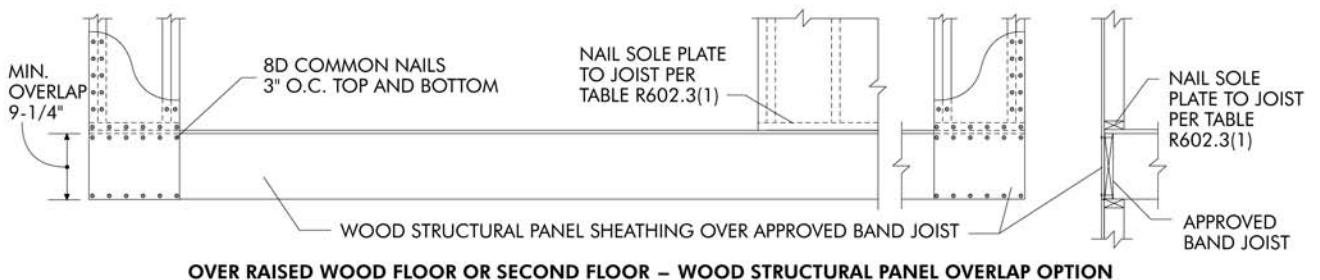
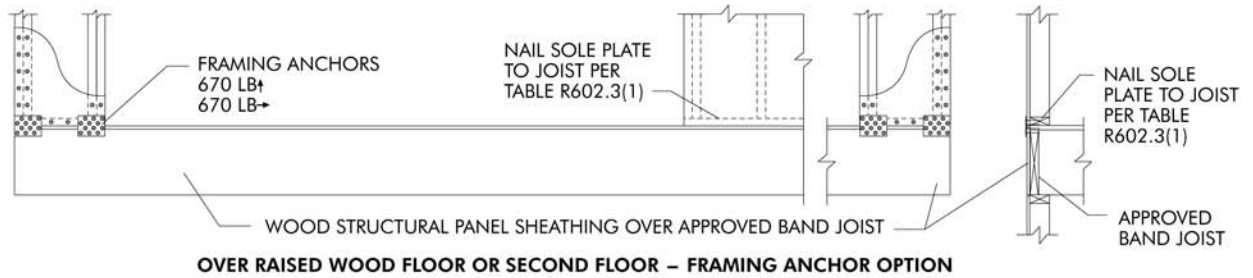
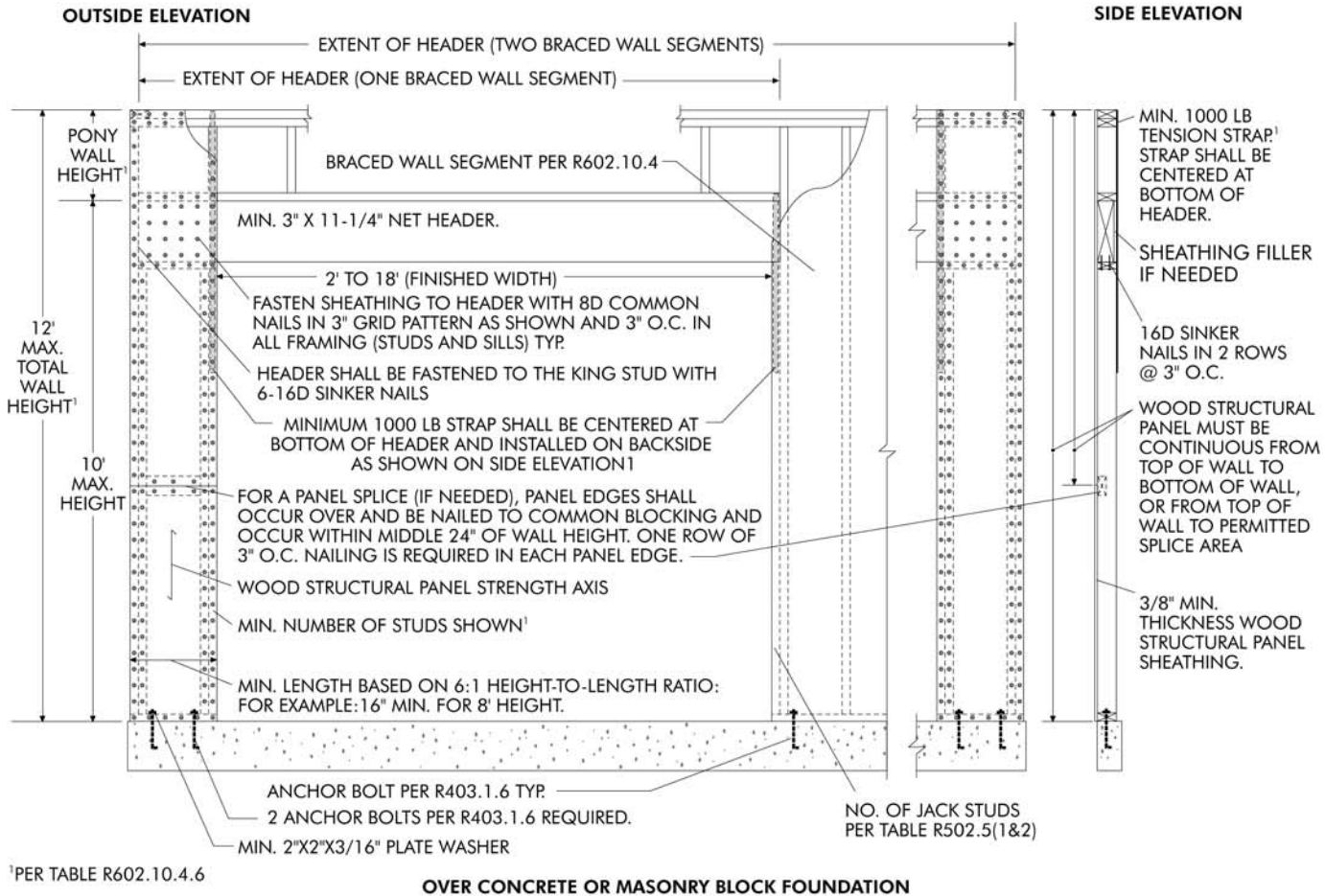

NOT TO SCALE

4) Braced wall panel support on masonry – General

Masonry stem walls of three (3) or less courses which are supporting braced wall panels may be un-reinforced, unless specifically required otherwise by code or design to be reinforced. Masonry stem walls up to 48" (i.e. 6 courses) which are supporting braced wall panels must be adequately reinforced. Reinforcement done in accordance with one of the following details is considered adequately reinforced.

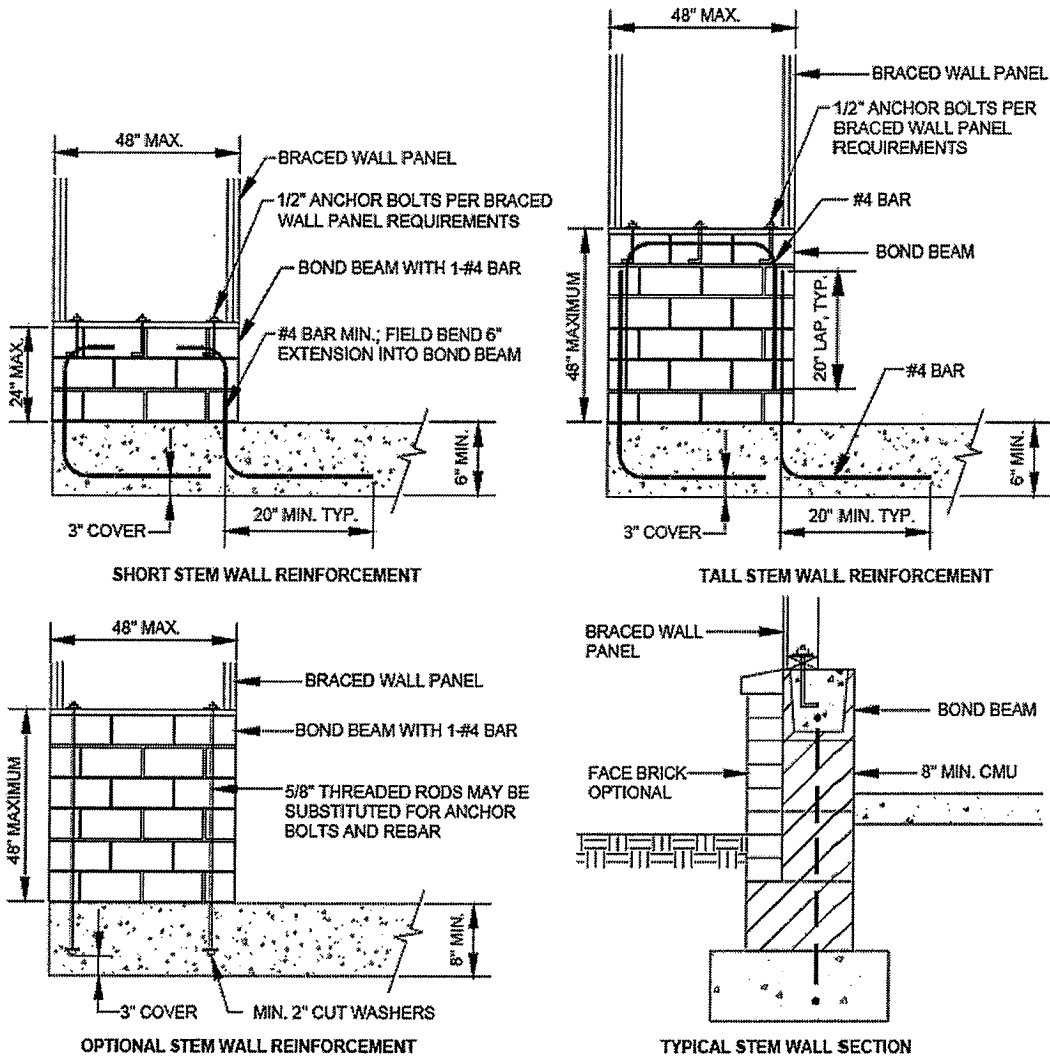

NOTE: GROUT BOND BEAMS AND ALL CELLS WHICH CONTAIN REBAR, THREADED RODS AND ANCHOR BOLTS.

MASONRY STEM WALLS SUPPORTING BRACED WALL PANELS

Proprietary Product Method (PPM)

This method incorporates proprietary products and methods that have demonstrated their ability to meet or exceed the prescriptive requirements contained within the Code and therefore have been approved by an agency, association or testing facility which has been determined to be acceptable by the Authority Having Jurisdiction (AHJ).

- Steel Strong – Wall on CMU Stem Wall Foundations: Garage Front
2000/2003/2006 IRC Prescriptive Wall Bracing: Wind & Low Seismic
Regions
- iLevel Engineered Lumber Products – Shear Brace
- Hardy Frame Panels – No additional engineering design is required in most situations for a maximum of three (3) courses unreinforced CMU's or 48 inches for reinforced CMU's.

June 6, 2008



**Re: Steel Strong-Wall on CMU Stem Wall Foundations: Garage Front
2000/2003/2006 International Residential Code Prescriptive Wall Bracing: Wind & Low Seismic
Regions**

To Whom It May Concern:

This letter provides Steel Strong-Wall (SSW) wall bracing solutions that may replace wider braced wall panels that are prescribed in the 2000, 2003, or 2006 International Residential Code (IRC) for wall heights up to 10 feet. This letter must be used in conjunction with our current Strong-Wall catalog (C-SW07).

The C-SW07 catalog provides SSW bracing solutions for *garage fronts* that anchor into concrete stemwalls. Table 1 of this letter provides wall bracing solutions for single story and first of two story *garage fronts* on CMU stem walls on top of concrete footings with foundation anchorage shown in Figure A of this letter. Construction of stem walls and concrete footing directly below Steel Strong-Wall shall be in conformance with the building code, Table 1, and Figure A.

Anchor bolts shall be installed into the concrete footing with Simpson Strong-Tie SE T High Strength Epoxy-Tie or AT Acrylic-Tie adhesive. Anchorage solutions assume the concrete strip footing has a compressive design strength of 2,500 psi min. See the current Simpson Anchoring and Fastening Systems catalog, C-SAS, for additional pertinent design and installation information.

This letter is limited to structures constructed in accordance with the IRC in the following climatic and geographic regions:

- Seismic:
 - Detached one- and two-family dwellings in Seismic Design Category A, B, & C
 - Townhouses in Seismic Design Categories A and B
- Wind:
 - 2000/2003 IRC: wind speeds less than 110 mph
 - 2006 IRC: wind speeds less than 100 mph in hurricane prone regions or less than 110 mph elsewhere

Please note: the information in this letter is valid until **12/31/2008** when it will be reevaluated by Simpson Strong-Tie. Except as noted in this letter, all information and instructions found in the *Strong-Wall Shearwalls* catalog, C-SW07, including the *General Notes – Prescriptive Wall Bracing* on page 60, apply. Refer to the current Simpson Strong-Tie *Wood Construction Connectors* catalog for other pertinent information. If you have any other questions or need further assistance regarding this matter, please contact the engineering department of Simpson Strong-Tie at 1-800-999-5099.

Sincerely,

SIMPSON STRONG-TIE CO., INC.

Encl.: *Table 1: Garage Front Solutions on CMU stem wall*
Figure A: CMU Stem wall
Figure B: SSW Anchor Bolt Layout

Table 1: Garage Front Solutions on CMU Stem Wall

Application	Wall Model	Rod Dia.	Anchor Embed. Depth, l_e		
			Min. Footing Width, W		
			16"	21"	24"
Single Story					
1 For 1 Substitution - One SSW Panel Required at each end of Wall					
	SSW12X7 ⁵	3/4"	NS	6 3/4"	6 3/4"
	SSW15X7	1"	6 3/4"	6 3/4"	6 3/4"
	SSW12X8 ⁵	3/4"	NS	6 3/4"	6 3/4"
	SSW15X8	1"	6 3/4"	6 3/4"	6 3/4"
	SSW15X9	1"	6 3/4"	6 3/4"	6 3/4"
	SSW15X10 ¹⁰	1"	6 3/4"	6 3/4"	6 3/4"
1 For 2 Substitution					
	SSW18X7	1"	NS	6 3/4"	6 3/4"
	SSW21X7	1"	NS ⁹	6 3/4"	6 3/4"
	SSW18X8	1"	NS	9"	6 3/4"
2 For 3 Substitution					
	SSW15X7	1"	NS	6 3/4"	6 3/4"
	SSW18X7	1"	6 3/4"	6 3/4"	6 3/4"
	SSW18X8	1"	NS ⁹	6 3/4"	6 3/4"
	SSW21X8	1"	6 3/4"	6 3/4"	6 3/4"
First Story of Two-Story					
1 For 1 Substitution - One SSW Panel Required at each end of Wall					
	SSW18X7	1"	6 3/4"	6 3/4"	6 3/4"
	SSW18X8	1"	NS ⁹	6 3/4"	6 3/4"
	SSW18X9	1"	NS	6 3/4"	6 3/4"
	SSW21X9	1"	6 3/4"	6 3/4"	6 3/4"
	SSW21X10 ¹⁰	1"	NS ⁹	6 3/4"	6 3/4"
1 For 2 Substitution					
	SSW21X7	1"	NS	NS	9"
	SSW24X7	1"	NS	9"	6 3/4"
	SSW24X8	1"	NS	NS ⁹	9"
2 For 3 Substitution					
	SSW21X7	1"	NS	6 3/4"	6 3/4"
	SSW24X7	1"	NS ⁹	6 3/4"	6 3/4"
	SSW21X8	1"	NS	9"	6 3/4"

- Required quantity of braced wall panels shall be determined from IRC Section R602.10.
- One-for-two and two-for-three substitutions require the header to frame over the SSW panel.
- Anchor rods shall be ASTM F1554 Grade 36 or ASTM A36 minimum.
- Solutions based on a 8-inch nominal grout filled CMU wall pier height of 48 inch maximum. The minimum CMU prism design compressive strength $f'_m = 1500$ psi. To achieve $f'_m = 1500$ psi, a minimum grout strength of 2,000 psi using standard ASTM C90 concrete masonry units and type M or S mortar is required.
- Where noted, solutions are limited to 32-inch tall maximum CMU wall pier heights, constructed per footnote #4, and require a standard hex nut directly under the SSW panel and flush with top of CMU stem wall.
- NS = No anchorage solution available.
- Anchor rods must be installed with Simpson Strong-Tie SET High Strength Epoxy or AT Acrylic-Tie into 2,500 psi minimum concrete footing. ATR shall be located as shown in Figure A.
- Minimum concrete temperature at time of installation is 0°F for AT and 40°F for SET.
- Where noted, anchor rods may be installed with Simpson Strong-Tie SET High Strength Epoxy with an anchor embedment depth, l_e , equal to 9 inches.
- Where noted, 10 foot tall walls shall be installed directly below top plates.

Figure A: CMU Stem Wall

CMU STEM WALL SHALL BE CENTERED ON CONCRETE FOOTING

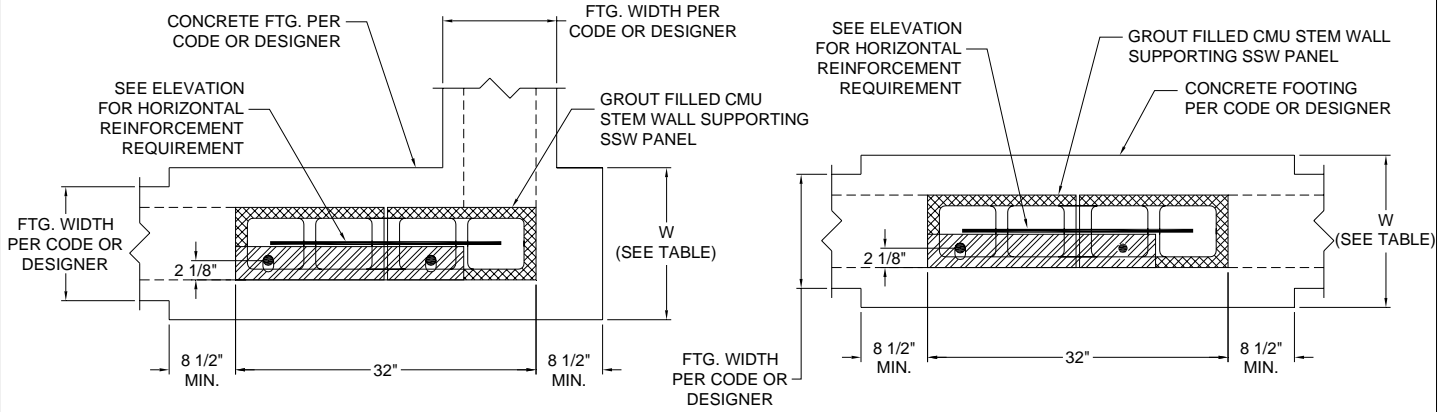

32" WIDE GROUT FILLED CMU STEM @ SSW24

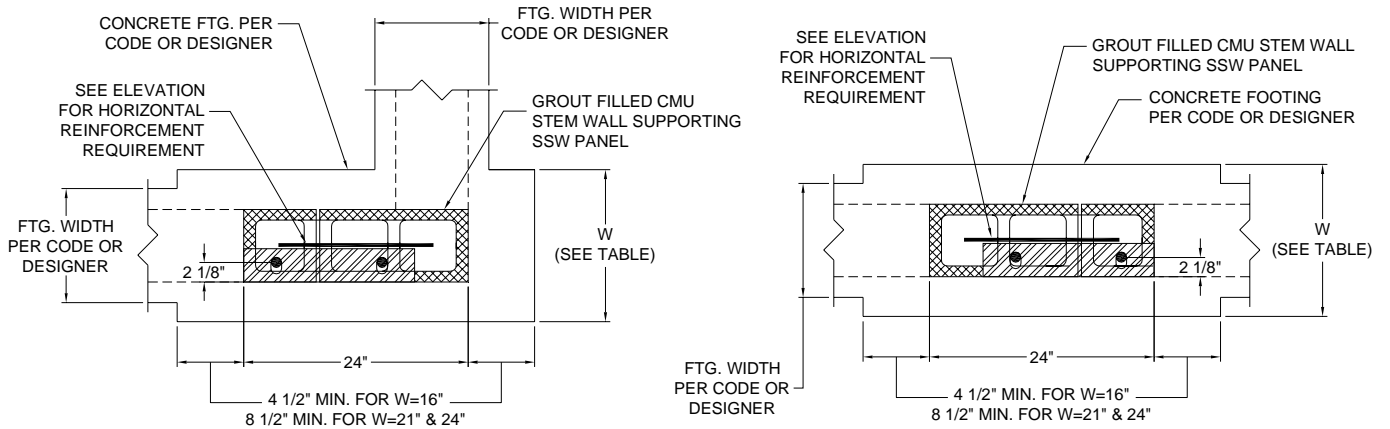

24" WIDE GROUT FILLED CMU STEM @ SSW18 & SSW21

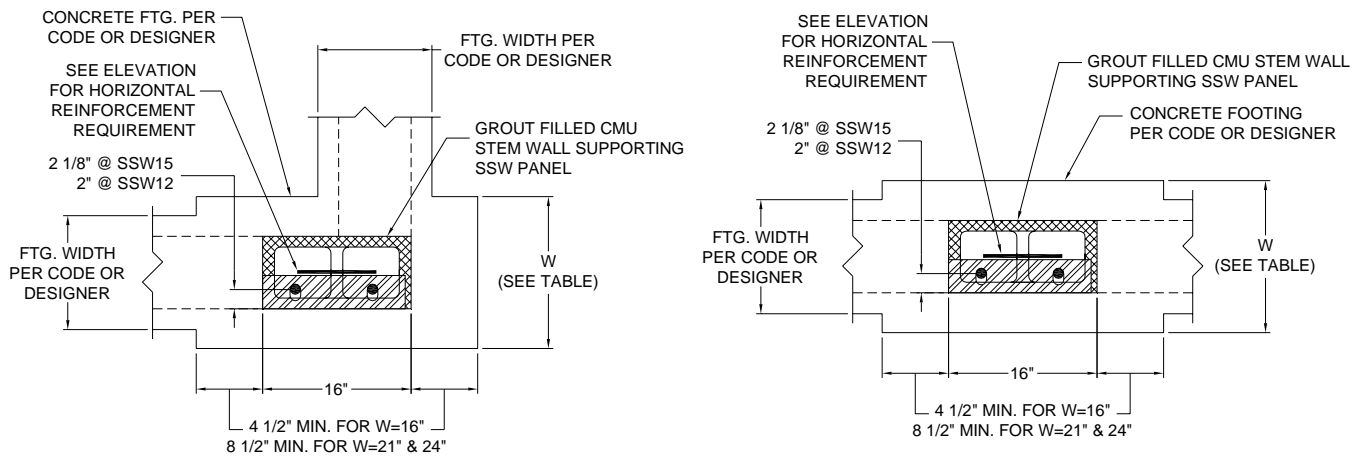

16" WIDE GROUT FILLED CMU STEM @ SSW12 & SSW15

Figure A continued: CMU Stem Wall

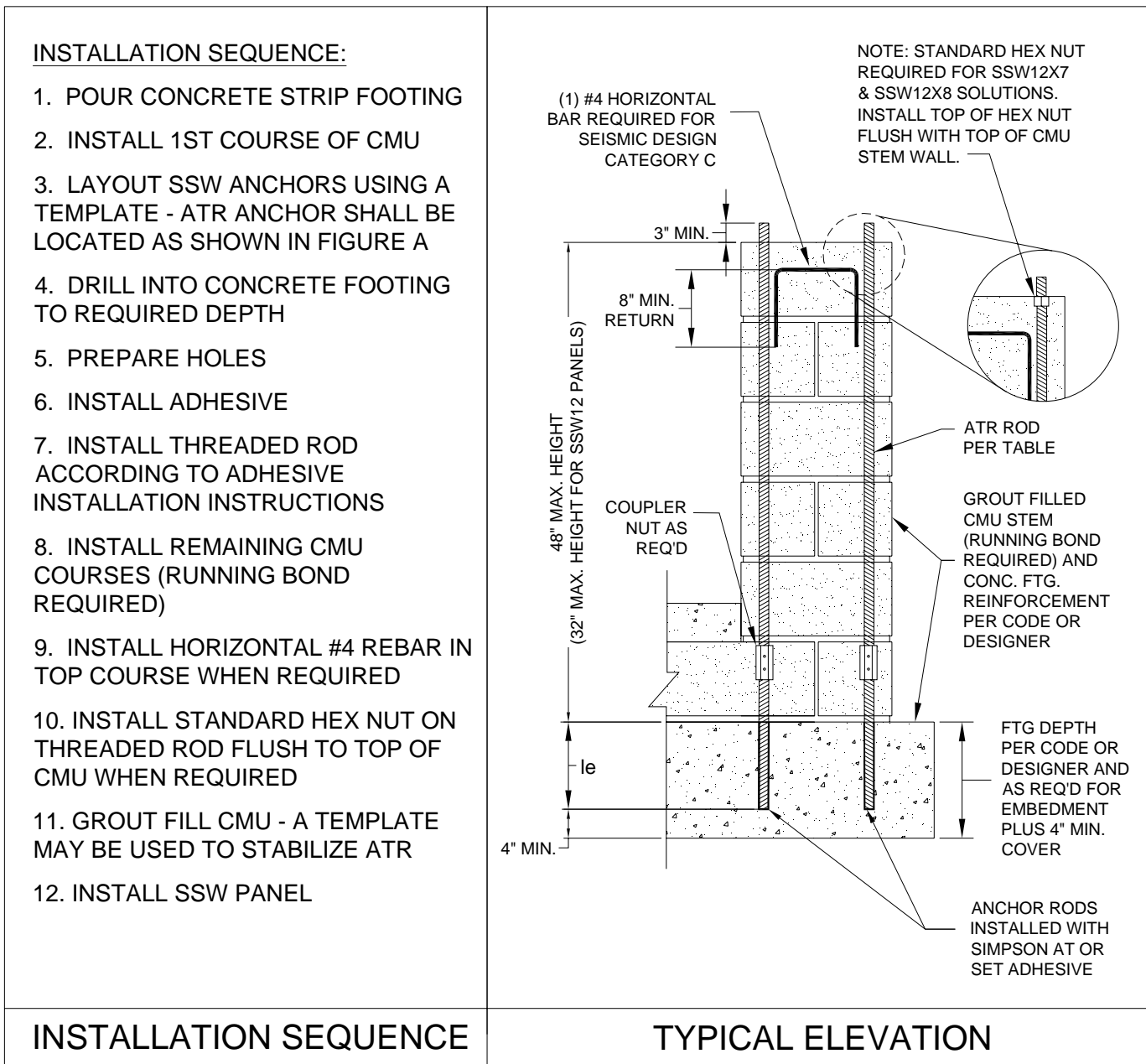
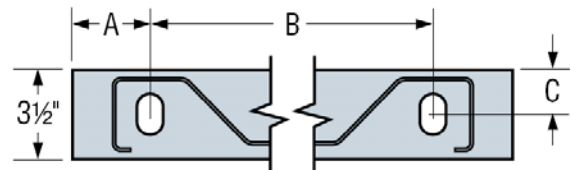

Figure B: SSW Anchor Bolt Layout

WALL MODEL	DISTANCE (A)	DISTANCE (B)	DISTANCE FROM EXT. FACE OF SSW PANEL TO ATR ANCHOR (C)
SSW12	2 9/16"	6 7/8"	2"
SSW15	2 7/8"	9 1/4"	2 1/8"
SSW18	2 7/8"	12 1/4"	2 1/8"
SSW21	2 7/8"	15 1/4"	2 1/8"
SSW24	2 7/8"	18 1/4"	2 1/8"



iLevel® Shear Brace

engineered lumber products

The iLevel® Shear Brace is a specially designed, prefabricated, engineered-wood panel that helps homes resist lateral forces such as those created by high winds and earthquakes. The iLevel® Shear Brace (iSB):

- **Can be substituted, 1-for-1, for any site-built, prescriptive brace panel**
- Narrow panel widths (12" and 18" width) with high allowable loads
- **Made of engineered wood – Easy to use and field adjustable – panels can be trimmed and drilled in the field**
 - 12" x 9' iSB can be trimmed down to 78"
 - 18" x 12' iSB can be trimmed down to 78"
- **Several different use applications: Garage portal frame, narrow wall spaces, tall wall panels with balloon framing, multi-story stacked applications**
- Convenient access for wiring – Pre-cut electrical access holes and concentric design allow for convenient wiring and plumbing
- Simple connection to the foundation – (2) 7/8" all-thread rods into the foundation
 - Installation details for concrete slab, concrete foundation with stemwall, and concrete masonry wall (CMU)
 - 6" embedment length (l_e) into footing

Local technical support:

John Ganschow – Structural Frame Specialist – 615-519-1057

Engineering Office – Adam Pittman, P.E. or Chad Wall, P.E. – 615-220-7210

Standard Installation

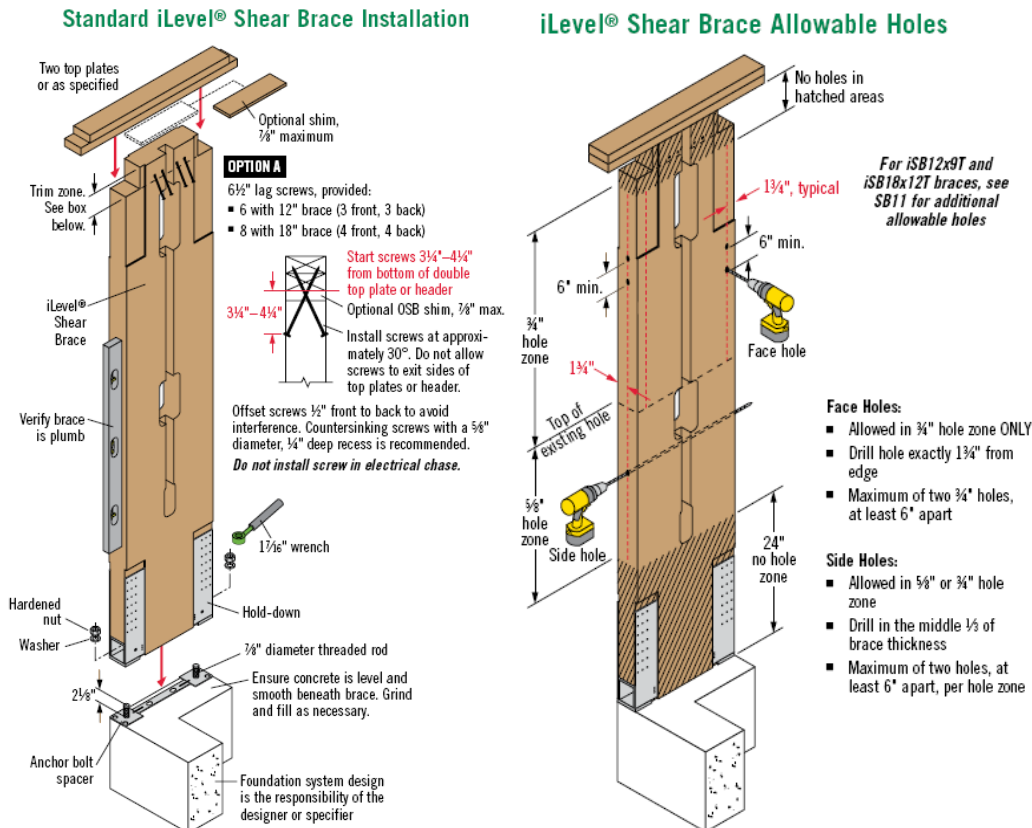

See iLevel® Shear Brace Specifier's Guide (TJ-8620) for more details.
www.iLevel.com

Portal Frame Installation

Portal Frame Shear Brace

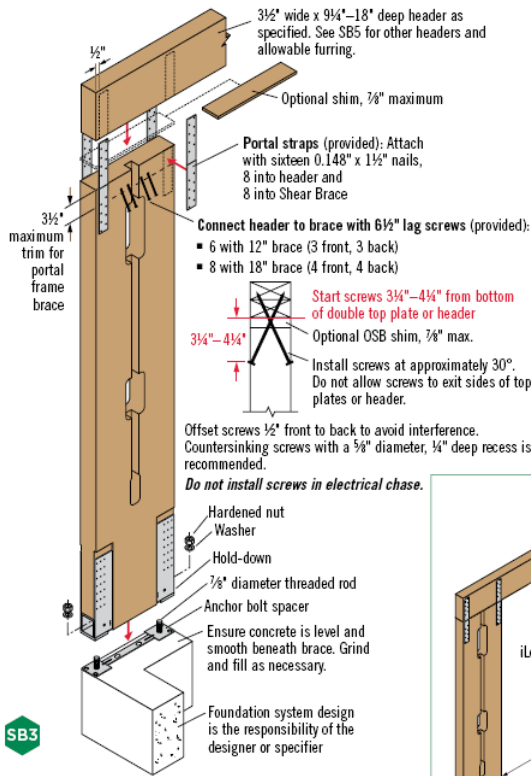

Portal Frame Column

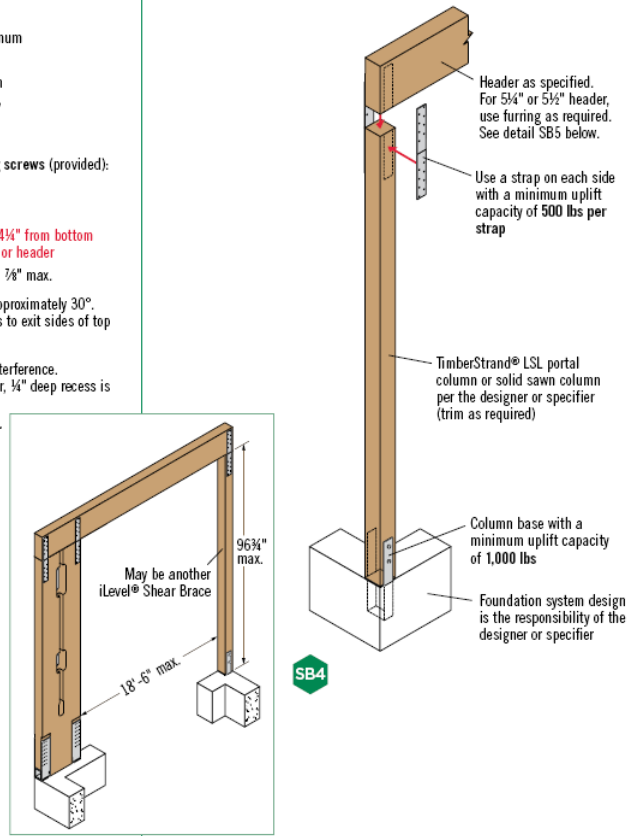

Anchorage

Detail 1

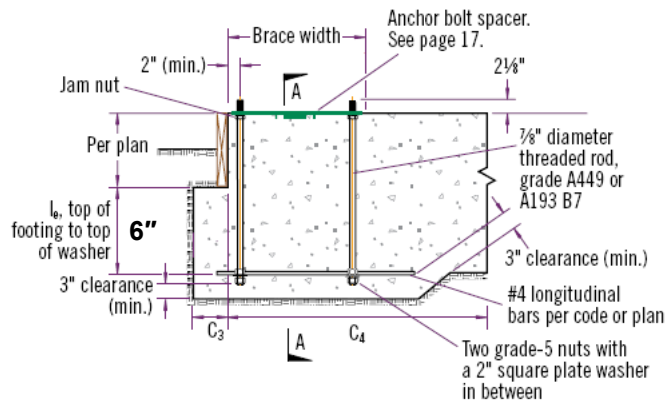
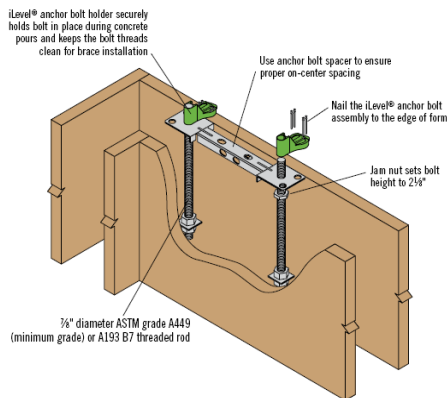

See iLevel® Shear Brace Specifier's Guide (TJ-8620) for more details.
www.iLevel.com

August 19th, 2008

Hardy Frame[®] Panels are pre-manufactured, cold formed steel shear walls that are approved as a **Proprietary Product Method (PPM)** to meet the 2006 IRC Code requirements for Prescriptive Wall Bracing.

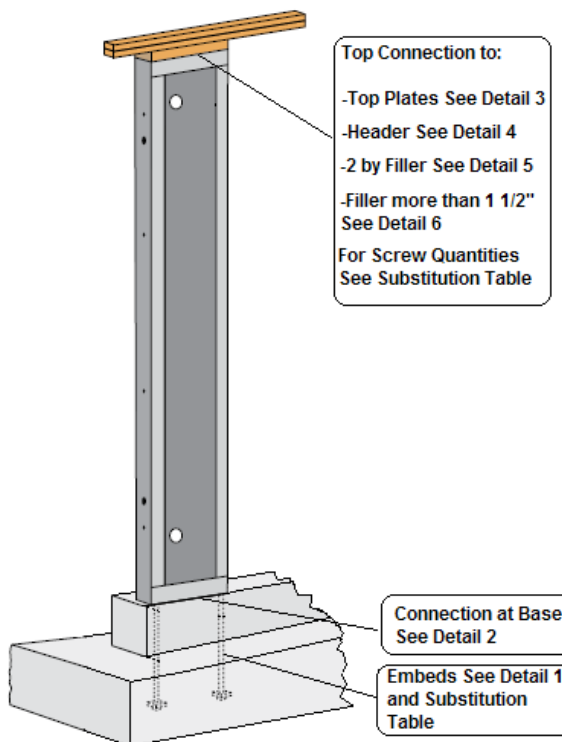

Features



- Standard widths of 12, 18 and 24 inches
- 1 for 1 substitution for Braced Wall and Alternate Braced Wall Panels
- 1 for 2 and 2 for 3 substitutions at garage fronts
- Garage front applications do not require continuous header (Portal)
- Easy top and bottom connections
- Electrical and plumbing access holes pre-punched
- Can be installed on concrete, masonry, raised floor and upper floor conditions
- Additional installations include stacking floor to floor and balloon wall
- Complete Wall Bracing Catalog and Typical Installation Details available

Sales and Support Contact: Doug Folker, Regional Manager (727) 642-0483

Technical Support Contact: Main Office (800) 754-3030

www.hardyframe.com

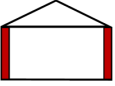
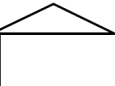
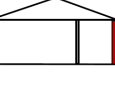
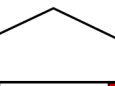
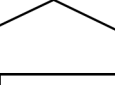
Hardy Frame[®] Panel Substitution for Braced Wall Panels at Slab on Grade and CMU Foundations

Replacement Scheme (Hardy Frame [®] Panels for Braced Wall Panels)	Model Number	Bolt ² Diameter (inches)	Hold Down Embeds ³ (inches)				Min Screw ⁴ Qty at Top	
			12 inch Footing Width		18 inch Footing Width			
			Depth (E _f)	Edge/End (d _{ef})	Depth (E _f)	Edge/End (d _{ef})		
Single Story								
1 for 1		HF78x12 7/8	7/8	6	6	6	9	5
		HF8x12 7/8	7/8	8	6	6	9	5
		HF9x12 7/8	7/8	8	6	6	9	5
		HF10x12 7/8	7/8	8	6	6	9	5
		HF78x18 7/8	7/8	6	6	6	9	5
		HF8x18 7/8	7/8	6	6	6	9	5
		HF9x18 7/8	7/8	6	6	6	9	5
HF10x18 7/8	7/8	6	6	6	9	5		
1 for 2		HF78x12 7/8	7/8	12	6	12	9	5
		HF78x18 7/8	7/8	8	6	6	9	5
		HF8x18 7/8	7/8	12	6	6	9	5
		HF9x18 7/8	7/8	12	6	8	9	5
		HF10x18 7/8	7/8	12	6	12	9	5
2 for 3		HF78x12 7/8	7/8	8	6	6	9	5
		HF8x12 7/8	7/8	12	6	8	9	5
		HF9x12 7/8	7/8	12	6	12	9	5
		HF78x18 7/8	7/8	6	6	6	9	5
		HF8x18 7/8	7/8	8	6	6	9	5
		HF9x18 7/8	7/8	8	6	6	9	5
		HF10x18 7/8	7/8	8	6	6	9	5
First of Two Story								
1 for 1		HF78x12 7/8	7/8	12	6	8	9	5
		HF8x12 7/8	7/8	12	6	12	9	5
		HF78x18 7/8	7/8	6	6	6	9	5
		HF8x18 7/8	7/8	8	6	6	9	5
		HF9x18 7/8	7/8	8	6	6	9	5
		HF10x18 7/8	7/8	12	6	6	9	5
1 for 2		HF78x18 7/8	7/8	12	6	12	9	8
		HF8x18-1 1/8	1 1/8	14	6	12	9	8
		HF9x18-1 1/8	1 1/8	14	6	14	9	8
		HF78x24 7/8	7/8	12	6	8	9	8
		HF8x24 7/8	7/8	12	6	12	9	8
		HF9x24 7/8	7/8	12	6	12	9	8
		HF10x24 7/8	7/8	12	6	12	9	8
2 for 3		HF78x18 7/8	7/8	12	6	8	9	8
		HF8x18 7/8	7/8	12	6	12	9	8
		HF9x18 7/8	7/8	12	6	12	9	8
		HF10x18 7/8	7/8	12	6	12	9	8
		HF78x24 7/8	7/8	8	6	6	9	8
		HF8x24 7/8	7/8	8	6	6	9	8
		HF9x24 7/8	7/8	12	6	8	9	8
		HF10x24 7/8	7/8	12	6	8	9	8

- 1) This table applies for Seismic Design Categories A, B, C and Wind Speeds less than 110 mph.
- 2) Bolts are ASTM A36 threaded rod with 1/2x3x3 ASTM A36 Plate Washers at embed end or Hardy Frame Bolt Brace.
- 3) Assumes 2500 psi (min) concrete strength. All depths, edge and end distances are in inches.
- 4) Use 1/4 x 3 inch wood screws. Complying screws are Hardy Frame HFS Series, USP "WS" Series (ICC-ES PFC-5634) or equal. When installing a 2x filler at the top connection, the minimum screw length is 4 1/2-inches. See Detail 5.
- 5) For fillers greater than 1 1/2" see Detail 6.

Detail 1 (Embeds)

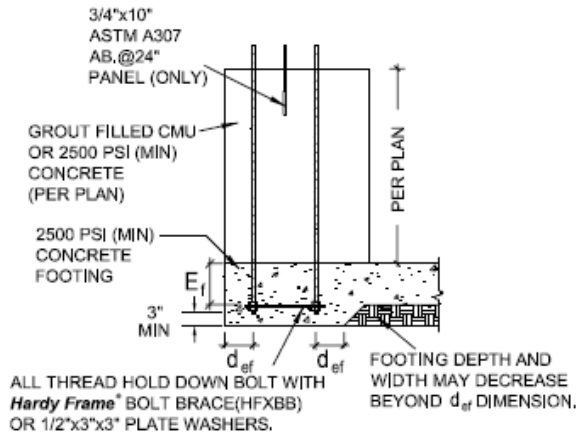

NOTE: 1) COUPLING NUTS MAY BE USED TO EXTEND ALL
THREAD LENGTH THROUGH GROUT FILLED CMU.
2) FOR ANCHORS POST INSTALLED INTO FOOTING
FOLLOW EPOXY MANUFACTURERS
RECOMMENDATION AND INSTRUCTIONS.

STEM WALL ELEVATION

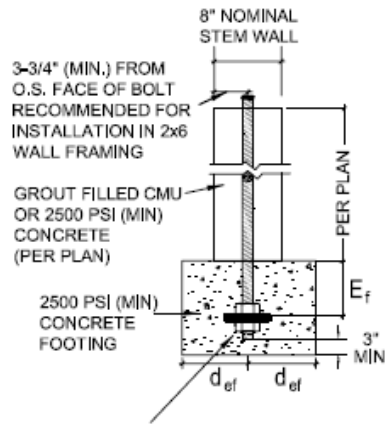

ALL THREAD HOLD DOWN BOLT WITH
Hardy Frame[®] BOLT BRACE (HFxBB)
OR 1/2"x3"x3" PLATE WASHERS.

STEM WALL SECTION

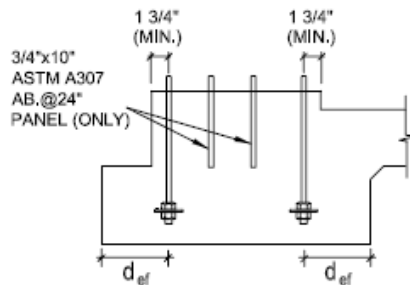

CURB ELEVATION

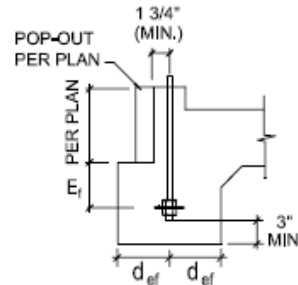

CURB SECTION

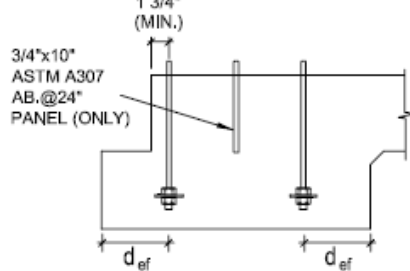

EXTERIOR SLAB ELEVATION

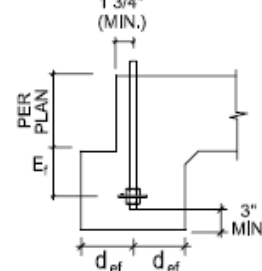

EXTERIOR SLAB SECTION

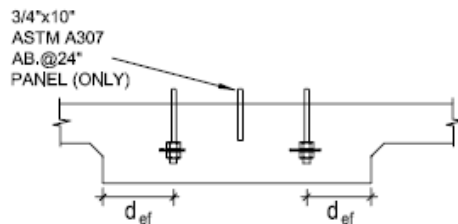

INTERIOR SLAB ELEVATION

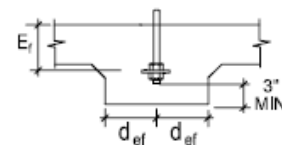

INTERIOR SLAB SECTION

¹Minimum concrete strength is 2,500 psi

²Minimum distance from inner most rod to the interior end of footing is $4 \times d_{ef}$

³Threaded rods and plate washers must comply with ASTM A36

⁴The embed depths (E_f) and edge/end distances are given in the Panel Substitution Table.

⁵Foundation design by others

⁶A qualified building designer is permitted to modify the requirements of these details.

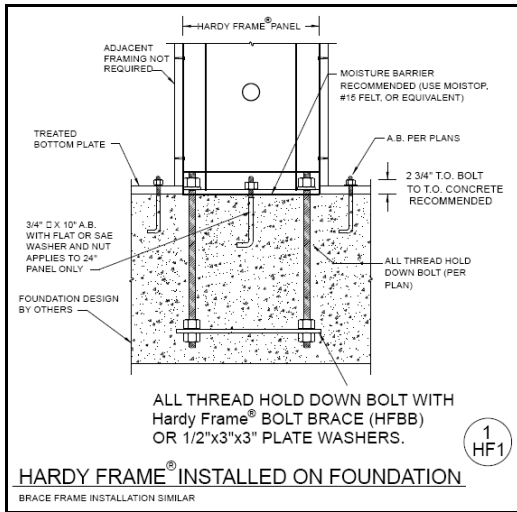

Detail 2

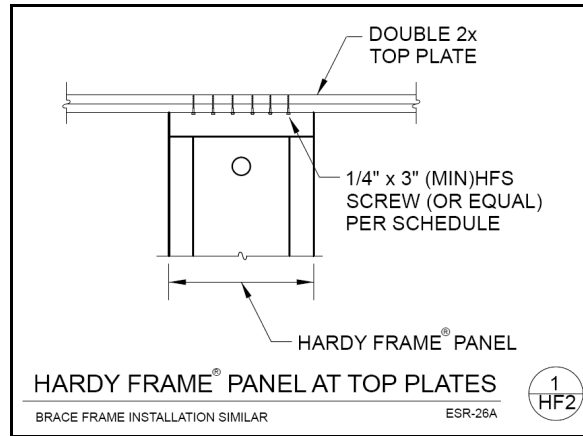

Detail 3

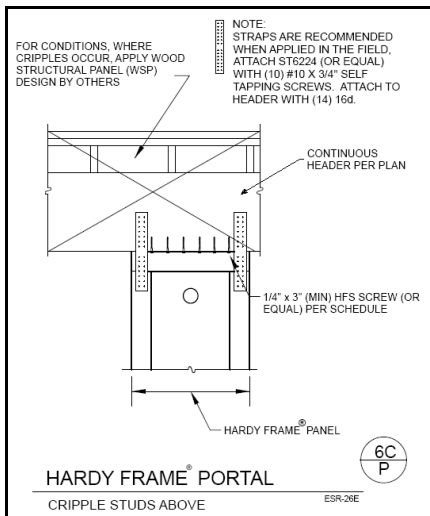

Detail 4

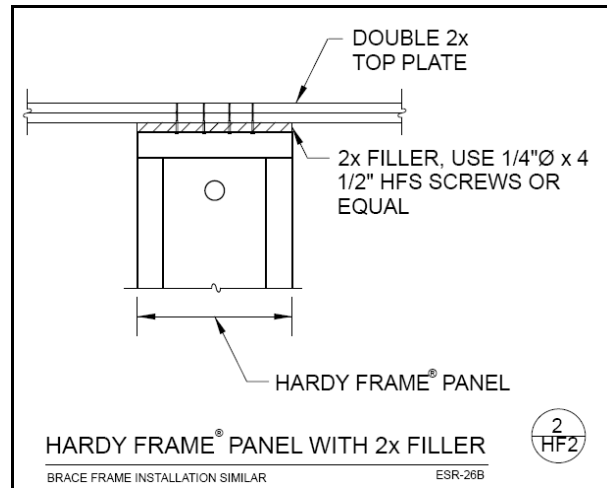

Detail 5

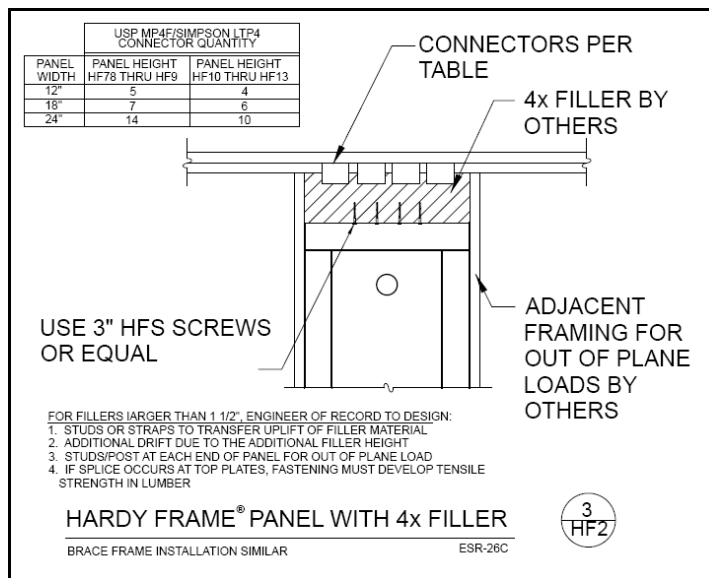

Detail 6